

LANKA FASTENER LIMITED

PHASE 2, I.P.Z., KATUNAYAKE 11420, SRI LANKA.

Tel : + 94 (0)11 2252750 Fax : + 94 (0)11 2252749

PRODUCT SPECIFICATION : UNI 5587
 PRODUCT RANGE : M3, M4, M5, M6, M8, M10, M12, M14, M16 & M20 in Steel
 M3, M4, M5, M6, M8, M10, M12, M14 & M16 in Stainless Steel
 Fine thread from M8

METERIAL	CARBON STEEL	STENLESS - A2	STENLESS - A4
Material Specification	1010 - 1015	304	316
Product Class	8	70	80
Proof Stress	800	700	800
Hardness (HRC)	18 - 25	22 - 34	22 - 34
Thread (ISO)	6H / 6G	6H	6H
Finish	Yellow / Blue Zinc & Plain	Passivated	Passivated
Proof load KN	As specified in ISO 898/2 & ISO 898 / 6		

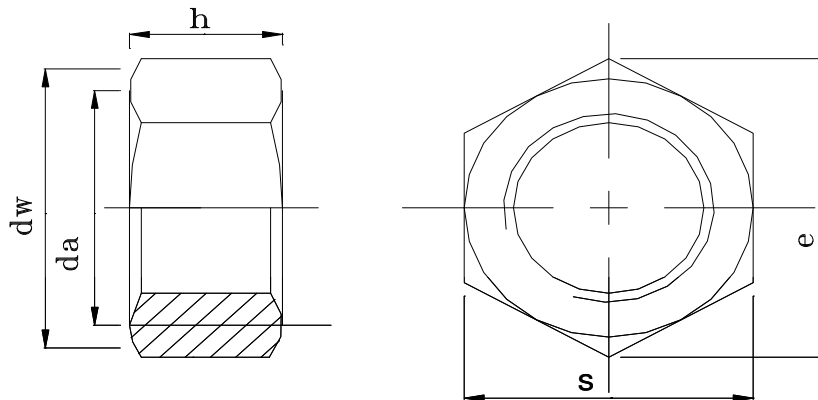

Type of Measurements	M3	M4	M5	M6	M8	M10	M12	M14	M16	M20
S	5.50	7.00	8.00	10.00	13.00	17.00	19.00	22.00	24.00	30.00
	5.38	6.85	7.85	9.78	12.73	16.73	18.67	21.67	23.67	29.67
h	3.00	4.00	5.00	6.00	8.00	10.00	12.00	14.00	16.00	20.00
	2.75	3.70	4.70	5.70	7.64	9.64	11.57	13.57	15.57	19.48
e	6.34	8.07	9.23	11.54	15.00	19.61	21.92	25.38	27.69	34.53
	6.01	7.66	8.79	11.05	14.38	18.90	21.10	24.49	26.75	33.53
da	3.45	4.60	5.75	6.75	8.75	10.80	13.00	15.10	17.30	21.60
	3.00	4.00	5.00	6.00	8.00	10.00	12.00	14.00	16.00	20.00
dw	5.50	7.00	8.00	10.00	13.00	17.00	19.00	22.00	24.00	30.00
	4.60	5.90	6.90	8.90	11.60	15.60	17.40	20.50	22.50	27.70
Unit Weight	0.41	0.86	1.36	2.60	5.90	13.20	18.65	28.90	38.02	

(All linear dimensions in mm)



Manufacturer of Steel & Stainless Steel Nuts

