

LANKA FASTENER LIMITED

PHASE 2, I.P.Z., KATUNAYAKE 11420, SRI LANKA.

Tel : + 94 (0)11 2252750 Fax : + 94 (0)11 2252749

PRODUCT SPECIFICATION : DIN 6923
 PRODUCT RANGE : M4, M5, M6, M8, M10 & M12 in Steel & Stainless Steel

METERIAL	CARBON STEEL	STENLESS - A2	STENLESS - A4
Material Specification	1010 - 1015	304	316
Product Class	8	70	80
Proof Stress	800	700	800
Hardness (HRC)	18 - 25	22 - 34	22 - 34
Thread (ISO)	6H	6H	6H
Finish	Yellow / Blue Zinc & Plain	Passivated	Passivated
Proof load KN	As specified in ISO 898/2 & ISO 898 / 6		

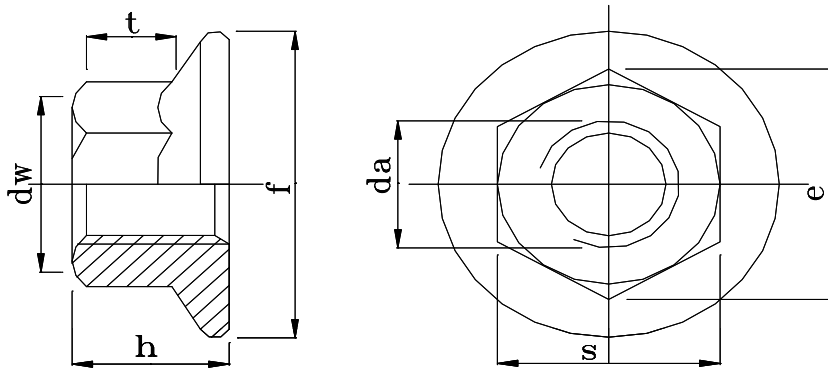

Type of Measurements	M4	M5	M6	M8	M10	M12
S	7.00	8.00	10.00	13.00	15.00	18.00
	6.78	7.78	9.78	12.73	14.73	17.73
h	4.60	5.00	6.00	8.00	10.00	12.00
	4.40	4.70	5.70	7.60	9.60	11.60
e	8.07	9.23	11.54	15.00	17.31	20.77
	7.66	8.79	11.05	14.38	16.64	20.03
f	10.00	11.20	13.50	17.50	21.00	25.00
	9.60	10.80	13.00	17.00	20.40	24.40
t	3.10	3.25	4.00	5.70	7.00	8.50
	2.90	3.05	3.80	5.50	6.75	8.25
da	4.60	5.75	6.75	8.75	10.80	13.00
	4.00	5.00	6.00	8.00	10.00	12.00
dw	7.00	8.00	10.00	13.00	15.00	18.00
	5.90	6.90	8.90	11.60	14.60	16.60
Unit Weight	1.28	1.70	3.44	7.39	11.16	19.32

(All linear dimensions in mm)



Manufacturer of Steel & Stainless Steel Nuts

